

Fosroc® Nitokit LV and Nitokit TH



constructive solutions

3
CI/SfB: Yr4
Sept 2015

Pre-packaged low viscosity or thixotropic epoxy crack injection systems

Uses

Nitokit LV and Nitokit TH are designed for injecting cracks in concrete and masonry where there is a need to consolidate a structure or exclude water and air from contact with reinforcement.

Nitokit LV is a low viscosity system and is suitable for cracks down to 0.2 mm at the surface and internal cracks tapering down to 0.01 mm.

Nitokit TH is a thixotropic system and can be injected into open ended cracks where depth and quantity of resin need to be controlled and minimum surface crack width is 2mm.

The Nitokit systems are ideal for small scale repairs on site and are also suitable for in-situ or precast concrete elements.

Advantages

- Self contained packs include everything necessary to complete the crack injection
- Convenient to use disposable cartridge contains both resin and hardener
- Safe and clean to use, non-return valves avoid leakage and spills
- High strength, excellent bond to concrete, brickwork and masonry
- Low viscosity and thixotropic options allow cost effective and efficient repair

Description

Nitokit LV or Nitokit TH basic pack incorporates a two-part epoxy crack injection resin contained in a patented single cartridge, complete with injection nipples and hoses. A selection of either Nitokit LV, a low viscosity system or Nitokit TH, a thixotropic system, ensures the most cost effective and efficient solution.

The Nitokit accessory pack contains additional items which are complementary to the basic pack — a two-part surface sealer and adhesive for fixing nipples and sealing cracks, an injection gun and eye protection.

Specification clauses

Low viscosity crack injection

The crack injection system shall be Nitokit LV. It shall be applied strictly in accordance with 'Application instructions' given in the product data sheet. It shall comply with EN1504-5.

Thixotropic crack injection

The crack injection system shall be Nitokit TH. It shall be applied strictly in accordance with 'Application instructions' given in the product data sheet. It shall comply with EN1504-5.

 0370	
Fosroc Ltd Drayton Manor Business Park, Coleshill Road, Tamworth, B78 3XN, UK 09 DOP: Nitokit LV UK9-193, Nitokit TH UK9-194 1305-CPD-1070	
Nitokit LV; Nitokit TH	
EN 1504-5: Concrete injection product Nitokit LV: U (F1) W(1) (1) (10/40) (1) Nitokit TH: U (F1) W(20) (1) (10/40) (1)	
Adhesion strength by pull-off test	> 2N/mm ²
Glass transition temperature	> 40°C
Adhesion by slant shear	monolithic failure dry - damp
Dangerous substances	NPD
Shrinkage	< 3%
Determination of injectability (Nitokit LV only)	>7 N/mm ²
Determination of adhesion of injection products	cohesive failure in substrate
Chloride ion content	NPD
Corrosion behaviour	Deemed to have no corrosive effect
Durability	Pass

Properties

Nitokit LV and Nitokit TH resin

Usable life at	10°C:	100 minutes
	20°C:	50 minutes
	30°C:	25 minutes
	40°C:	15 minutes
Viscosity at (Nitokit LV only)	10°C:	400 to 800 mPas
	20°C:	250 to 500 mPas
	30°C:	100 to 250 mPas
Set time at	10°C:	12 hours
	20°C:	7 hours
	30°C:	5 hours
	40°C:	3 hours
When cured for 7 days at 20°C		
Compressive strength:	> 70 N/mm ² (BS 6319)	
Flexural strength:	> 45 N/mm ² (ISO R178)	
Tensile strength:	> 55 N/mm ² (ISO 527)	
Modulus of elasticity:	2800 N/mm ²	
Elongation at break:	2.5%	
Tensile bond strength:	When tested to BS 3900, Pt E10 in both dry and wet states is greater than average concrete	

Fosroc® Nitokit LV and Nitokit TH

Nitokit Surface Sealant

Usable life at 20°C:	15 to 35 minutes dependent on mix ratio and quantities
Set time at 20°C:	1 to 2 hours dependent on mix ratio

Application instructions

Personal protection

Refer to 'Health and safety' section of this data sheet before commencing work.

Surface preparation

Nitokit Surface Sealant has to retain the injection system under pressure. Care must be taken to provide a bond surface which is dry and free from any contamination.

Mixing the surface sealant

Only mix enough sealant that can be applied within the usable pot-life. Pour a small quantity of the resin into the mixing bucket provided and slowly add the powder. Stir until a smooth thick cream consistency is obtained.

Application of the surface sealant

Immediately after mixing, apply a small amount of sealant to the back of each nipple ensuring that the valve will not be blocked, then place the nipple to ensure the valve (centre) is firmly over the crack. Nipples should be placed between 200 and 500 mm apart dependent on crack size. Additional sealant should be applied to the flange of the nipple to ensure a resin-tight seal to the substrate. Nitokit Surface Sealant should be knifed into the crack between nipples to ensure a resin-tight seal.

Where cracks can be sealed on one side only, nipples should be placed at centres which are 80% of the depth to which the resin is required to penetrate.

Application of the injection resin may commence as soon as the Nitokit Surface Sealant has fully hardened (at least 1 hour at 20°C or 2 hours at 10°C).

Mixing Nitokit LV epoxy resin

Lightly tap the side of the resin capsule near the base with a hammer two or three times on different sides to break internal glass container of hardener. (The glass can be heard moving when broken.)

To mix the resin, invert the cartridge twenty to thirty times slowly. Do not shake vigorously otherwise air will be incorporated.

Pierce the foil sealed threaded end of the cartridge.

Screw the Nitokit LV hose on to the cartridge. Ensure the 'O' ring is in place on the cartridge. Do not over tighten the fitting as this may distort the 'O' ring.

Use the mixed material within the useable life.

Mixing Nitokit TH epoxy resin

Cut the top off the conical nozzle and insert T-shaped rod and turn clockwise to engage mixing head in cartridge. (Figure 1).

Push rod down the full length of the cartridge to break the membrane separating the resin and hardener.

Pump up and down thirty to forty times to mix resin and hardener. (Figure 2).

Turn the T-shaped rod anti-clockwise to disengage and then remove. Do not shake.

Unscrew the conical nozzle and discard.

Screw the Nitokit hose onto the cartridge. Ensure the rubber 'O' ring is in place on the cartridge. Do not over tighten the fitting as this may distort the 'O' ring. (Figure 3).

Use the mixed material within the usable life.

Injection of Nitokit LV / TH Resin

Place the cartridge into the gun supplied with the accessory pack.

Push the free end of the Nitokit hose on to the lowest nipple and tighten the locking cap. Do not over tighten.

Insert an air release pin into the next nipple adjacent to the injection point. Note: do not start pumping until the air release pin is inserted to release the non-return valve and enable it to release trapped air.

Commence pumping slowly. Do not use excessive pressure. The rate of acceptance into fine cracks may be very slow. (Figure 4).

When resin appears at the nipple adjacent to the injection point:

- Stop pumping.
- Release the pressure on the injection gun.
- Remove the air release pin.
- Unscrew the cap and, with a twisting movement, pull off the Nitokit hose.

Attach the Nitokit hose to the next nipple, insert air release pin in the nipple beyond and recommence pumping.

Repeat the process until the entire length of crack has been injected.

On completion of pumping, the last cartridge can be left connected and pressurised slightly to allow for possible seepage into deep-seated cracks.

Making good

After the Nitokit injection resin has set, remove the nipples. These can be knocked off with a hammer. Make good any holes or voids with Nitokit Surface Sealant. The existing surface sealant can then be removed by either grinding or heating with a hot air gun and scraping the concrete surface until the original substrate profile is restored.

Fosroc® Nitokit LV and Nitokit TH

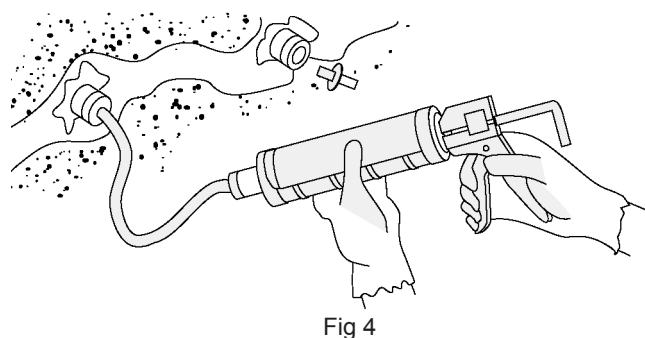
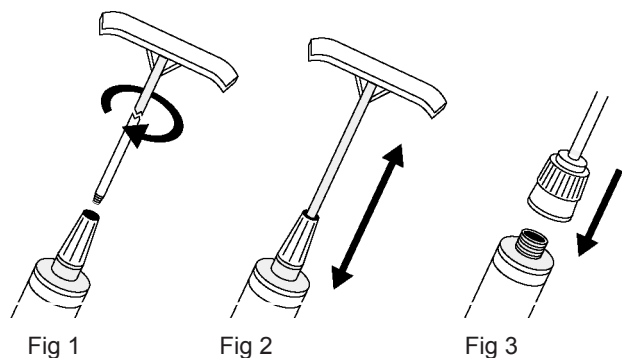

Also available separately

Nitokit injection nipples:	Each
Nitokit TH hoses:	Each
Nitokit air release pins:	Each
Nitokit Surface Sealant:	5.5 litre pack

Limitations

Nitokit LV and Nitokit TH should not be used for cracks where movement is expected to continue. Other measures should be taken to accommodate such movement, ie cutting and forming a movement joint.

Storage

Nitokit LV, Nitokit TH and Nitokit Surface Sealant have a shelf life of 12 months and should be stored in internal dry conditions at temperatures between 8°C and 25°C.

Precautions

Health and safety

For further information refer to appropriate Product Safety Data Sheet.

Fire

Nitokit LV and Nitokit TH are non-flammable.

Nitokit Surface Sealant and Fosroc Solvent 102 and 105 are flammable. Do not use near naked flames. No Smoking during use. In the event of fire extinguish with dry powder or CO₂. Do not use water jet.

Flash point

Nitokit Surface Sealant:	29°C
Fosroc Solvent 102	38°C
Fosroc Solvent 105	43°C

Cleaning

Tools and application equipment should be cleaned using Fosroc Solvent 102 for Nitokit TH and Nitokit LV and Fosroc Solvent 105 for Nitokit Surface Sealant.

Estimating

Nitokit LV & Nitokit TH	12 cartridges - (0.25 litre of mixed resin per cartridge)
(basic pack):	30 injection nipples
	6 hoses
	4 air release pins
	(Nitokit TH also includes 6 mixing rods)

Nitokit

(accessory pack):	1 injection gun
	1 plastic bucket
	2 pairs goggles
	1 x 5.5 litre pack Nitokit Surface Sealant

Fosroc and Nitokit are trade marks of Fosroc International Limited



Important note

Fosroc products are guaranteed against defective materials and manufacture and are sold subject to its standard Conditions for the Supply of Goods and Services, copies of which may be obtained on request. Whilst Fosroc endeavours to ensure that any advice, recommendation, specification of information it may give is accurate and correct, it cannot, because it has no direct or continuous control over where or how its products are applied, accept any liability either directly or indirectly arising from the use of its products, whether or not in accordance with any advice, specification, recommendation of information given by it.

Fosroc Limited

Drayton Manor Business Park
Coleshill Road, Tamworth,
Staffordshire B78 3XN. UK

www.fosroc.com

telephone:
+44 (0) 1827 262222

fax:
+44 (0) 1827 262444

email:
enquiryuk@fosroc.com

